

REVISIONS		
NO.	BY	DESCRIPTION
△		
△		

기본사양		
1	MODEL	ZBS25-300L-1-F1
2	재질	STS 304계열
3	후처리	POLLISING
4	배관형식	25A HOSE or STEEL PIPING
5	INLET PORT	25A FRONT 1PORT
6	슬릿 간격	1mm
7	풍속편차	±3% 이내
8	유효길이	300mm
9	취부형식	BRACKET 제공(각도 조절 TYPE)

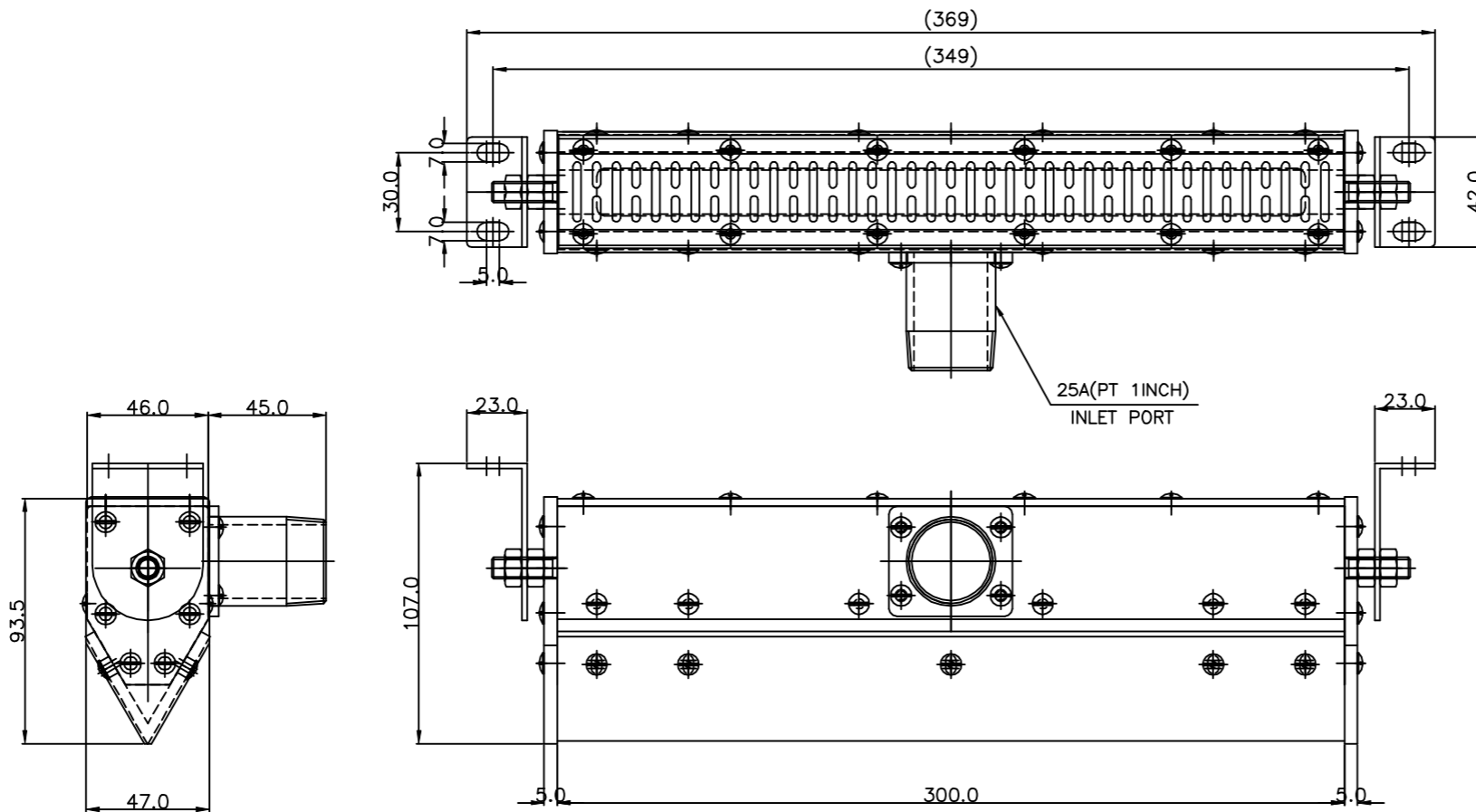

\*\*제작 유효길이: (MIN)100mm~(MAX)2700mm 까지 제작가능함.

**NOTE**

- 날카로운 모서리 제거할것.
- BOLT HOLE간 거리 허용공차 ±0.2 이내일것.



MACHINING		CANNING		RANGE OF SURFACE ROUGHNESS(μ)	
DIMENSION	TOL	DIMENSION	TOL	100-S	25-S
1-4	±0.1	less than 250	±1.5	▽	▽▽▽
4-16	±0.2	250-500	±2.0	▽	▽▽
16-63	±0.3	500-1000	±3.0	▽	▽
63-250	±0.5	1000-2000	±4.5	▽	
250-1000	±0.8	2000-4000	±6.0		
1000-2000	±1.0	4000-8000	±8.0		
2000-5000	±1.5				

NO	DESCRIPTION	SPECIFICATION	Q'TY	MATER'L	WEIGHT	REMARKS
DATE	2021.04	WEIGHT	SCALE	CUSTOMER		
		Kg	1 / 1			
DRAWN BY	DESIGNED BY	CHECKED BY	APPROVED BY	TITLE		
				ZBS25-300L-1-F1		
				AIR KNIFE ASS'Y		
				DRAWING NO.	REV	
				MBA-25A-000	△	
				A2(594X420)		

Moobico.,Ltd.